

RWH/HE

HEAT RECOVERY UNITS WITH ROTARY WHEEL



INTRODUCTION

Any occupied room requires the correct supply of fresh air and, at the same time, the control of the internal thermo-hygrometric conditions, through the recovery of energy from the air extracted from the room, by means of rotary wheel heat recovery, the level of well-being of the occupants is guaranteed, both in summer and winter.

For buildings that require air changes and are not equipped with dedicated air conditioning systems, the installation of such units allows the supply of primary air at controlled temperature without substantially changing the internal conditions in the occupied spaces.

These units also make it possible to guarantee support for the air conditioning system in the intermediate seasons using free-cooling or free-heating modes.

These units, if installed on existing buildings, guarantee the energy requalification of the system through the management of the air change without additional charges; in the case of new installations, instead, the air change is completely carried out allowing to reduce the size of the main air conditioning system.

In the intermediate seasons the building will benefit from free or partially-generated cooling from these units, which during the partial load phases allow the main system to operate with higher efficiency.



MAIN CHARACTERISTICS

STRUCTURE AND PANELS

The structure of the units can be realized in two versions:

VERSION 1:

Profiles 50 x 50 mm in self-supporting extruded anodized aluminium, with mechanical strength requirements in accordance with BS EN 1886: D1 (M). 50 mm thick double wall sandwich type paneling with exterior in pre-painted RAL 9010 galvanized sheet steel and interior in hot-dip galvanized sheet steel with interposed insulation made of polyurethane foam with a density of 40 kg/m³.

This structure has a seal class L1 while the thermal transmittance and the thermal bridge characteristic is class T3/TB4 according to EN1886.

VERSION 2:

Thermal break profiles 60 x 60 mm in self-supporting extruded anodized aluminium, with mechanical strength requirements in accordance with BS EN 1886: D1 (M). 63 mm thermal break sandwich-type double-walled sandwich-type panels with exterior in pre-painted RAL 9010 galvanized sheet steel and interior in hot-dip galvanized sheet steel with interposed insulation made of polyurethane foam with a density of 40 kg/m³.

This structure has a seal class L1 while the thermal transmittance and the thermal bridge characteristic is class T2/TB2 according to EN1886.

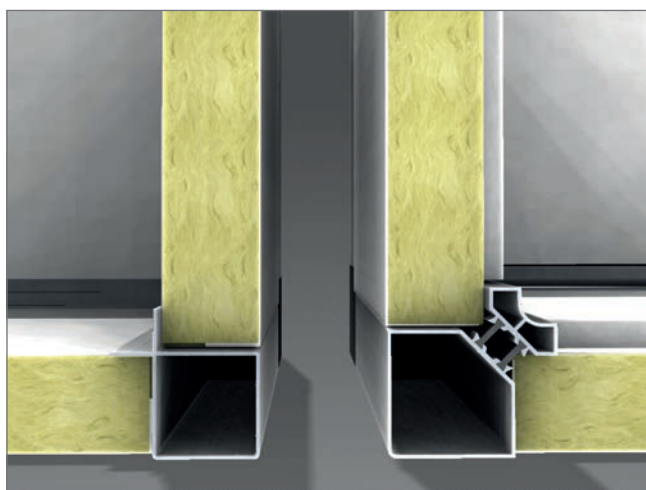

PROFILE 50 mm | PROFILE 60 mm

Safety microswitches are applied to the inspection doors to allow internal access to the various compartments of the unit only when the unit is completely switched off.

The main access and inspection panels consist of inspection doors with perimeter hinges made of non-corrosive polyamide and handles.

All units can be supplied in both monobloc and modular sections for on-site assembly when required.

AIR FILTERS

ePM₁₀ 60% (M5) filters in return air and ePM₁ 55% (F7) rigid bag filters in fresh air. Both types of filters are mounted on slides equipped with gaskets to ensure effective sealing. Their position, upstream of the internal components, also guarantees their protection.



AIR FILTERS

FANS

The units are equipped with high efficiency plug-fan type fans with built-in brushless EC motor. In this way it is possible to guarantee an accurate regulation of the airflow both in the supply and return section, ensuring that all regulatory requirements such as SFP are met.

The airflow rate of the fan is managed through the integrated electronic control system thus ensuring, according to the needs of the system, that the correct operation of the unit is maintained with consequent saving of the energy absorbed by the unit. The fans are fixed to the frame by means of self-centering brackets to ensure the correct distance between the impeller and the nozzle, thus optimizing performance.

HEAT RECOVERY

The units are equipped with an air-to-air rotary heat recovery unit, consisting by a cylindrical rotor containing thousands of channels and characterised by an extremely elevate surface development, a supporting frame, and an electric motor drive system. The heat exchange surface, very high in relation to the volume, allows very high thermal performances when compared to other types of heat recovery systems, reaching efficiencies even above 80%. In rotary wheel heat recovery units the heat exchange takes place by accumulating the heat in the rotor; as a matter of fact while the cylinder rotates slowly, the exhaust air volume crosses half of the casing and gives its heat to the rotor matrix, which accumulates it. The fresh air, crossing the other half, absorbs the accumulated heat. The parts absorbing and releasing the heat are continuously inverted, as the rotation proceeds, and the process may continue indefinitely. The heat exchanger participates to the

Eurovent Certification program and it is sized according to the **ECO Design** specification.



CONTROL

The units are supplied complete with control system and available in the versions **ECO**, **PLUS** and **TOP**.

ECO: complete with air temperature sensors installed on the fresh air intake and on room return air. The control allows to select, in stepless mode, the supply and return fan speeds and automatically manages the heat recovery by-pass damper through the motorized On/Off control, summer/winter seasonal change over, and programming for daily time zones. An optional hot water or cold water coil may also be managed, controlled by a 3-way modulating valve through the room return air sensor. The optional electric post-heating coil is also managed in modulating mode (always via the room return air sensor). The control alerts the user when filters need replacing (the clogged state of the filters is monitored by a pair of differential pressure switches supplied as standard) or the onset of any alarm; this may also be integrated into modern home automation systems via RS485 serial port with Modbus protocol.

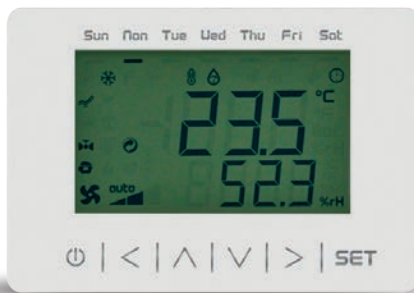

LCD REMOTE DISPLAY
(ECO version only)

PLUS: this control option is set to operate at constant pressure, it is supplied complete with pressure transducer and air temperature sensors installed on the fresh air intake and room return air. The control system allows to select, in stepless mode, the supply and return fan speeds and automatically manages the heat recovery by-pass damper through the motorized On/Off control. It also manages the summer/winter seasonal change over and programming for daily time zones.

The control can also manage an optional hot water or cold water coil through a 3-way modulating valve and an additional supply air sensor in order to maintain a fixed point operating logic.

The same logic can also be used to manage an electric post-heating coil, if present. The control alerts the user when filters need replacing (the clogged state of the filters is monitored by a pair of differential pressure switches supplied as standard) or the onset of any alarm; this may also be integrated into modern home automation systems via RS485 serial port with Modbus protocol.

TOP: this control option is set to operate at constant air-flow, it is supplied complete with pressure transducer and air temperature sensors installed on the fresh air intake and room return air.

The control system allows to select, in stepless mode, the supply and return fan speeds and automatically manages the heat recovery by-pass damper through the motorized On/Off control.

It also manages the summer/winter seasonal change over and programming for daily time zones. The control can also manage an optional hot water or cold water coil through a 3-way modulating valve and an additional supply air sensor in order to maintain a fixed point operating logic. The same logic can also be used to manage an electric post-heating coil, if present.

The system alerts to the user when filters need replacing (the clogged state of the filters is monitored by a pair of differential pressure switches supplied as standard) or the onset of any alarm and this may also be integrated into modern home automation systems via RS485 serial port with Modbus protocol.



LCD REMOTE GRAPHIC DISPLAY
(PLUS and TOP versions only)

TECHNICAL DATA

MODEL		010	020	030	045	060
Type of ventilation unit		UVNR-B (Non Residential Ventilation Units - Bidirectional)				
Type of drive installed		Analog signal on EC fan (0-10Vdc)				
Type of fans	type/nr.	EC/2	EC/2	EC/2	EC/2	EC/2
Type of heat recovery system (HRS)	type/nr.	rotary wheel / 1				
Winter Thermal Efficiency (η_{t_nrvu}) ⁽¹⁾	%	81,1	80,9	80,7	80,7	80,9
Nominal airflow rate	m ³ /h	1000	2000	3000	4500	6000
Electrical power consumption	kW	0,49	0,91	1,29	2,28	2,82
Installed electrical power	kW	1,03	1,54	2,50	3,84	5,18
SFP _{int}	W/(m ³ /s)	822	802	750	1031	829
SFP _{lim} 2018	W/(m ³ /s)	1301	1254	1206	1144	1087
Front speed at design range	m/s	1,07	1,24	1,21	1,67	1,67
External nominal pressure $\Delta p_{s, ext}$ ⁽²⁾	Pa	250	250	250	250	250
Internal pressure drop $\Delta p_{s, int}$ Ret./Supp.	Pa	205 / 226	226 / 251	216 / 234	290 / 319	240 / 274
Fans static efficiency (UE) n.327/2011	%	52,3	59,8	60,8	60,1	62,5
Max. external / internal leakage percentage	%	L1 max 5,0 % at +250 Pa				
Energy classification filters		ePM1 65% (F7) ePM10 65% (M5)				
Filter pressure switch		present				
Sound power level ⁽³⁾	dB(A)	64,0	66,0	63,0	69,0	69,0
Sound pressure level ⁽⁴⁾	dB(A)	52,0	54,0	51,0	57,0	57,0
Power supply	V/ph/Hz	230/1/50		400/3/50		

MODEL		080	100	130	170	240
Type of ventilation unit		UVNR-B (Non Residential Ventilation Units - Bidirectional)				
Type of drive installed		Analog signal on EC fan (0-10Vdc)				
Type of fans	type/nr.	EC/2	EC/2	EC/4	EC/4	EC/4
Type of heat recovery system (HRS)	type/nr.	rotary wheel / 1				
Winter Thermal Efficiency (η_{t_nrvu}) ⁽¹⁾	%	80,7	80,6	79,0	79,1	79,0
Nominal airflow rate	m ³ /h	8000	10000	12800	16700	21500
Electrical power consumption	kW	3,79	4,73	6,46	8,32	10,59
Installed electrical power	kW	5,98	7,08	10,37	11,97	23,17
SFP _{int}	W/(m ³ /s)	890	911	959	954	949
SFP _{lim} 2018	W/(m ³ /s)	1031	1028	980	983	980
Front speed at design range	m/s	1,65	1,75	2,16	2,03	2,03
External nominal pressure $\Delta p_{s, ext}$ ⁽²⁾	Pa	250	250	250	250	250
Internal pressure drop $\Delta p_{s, int}$ Ret./Supp.	Pa	253 / 291	261 / 301	282 / 314	278 / 313	274 / 305
Fans static efficiency (UE) n.327/2011	%	62,5	62,8	62,0	61,6	61,4
Max. external / internal leakage percentage	%	L1 max 5,0 % at +250 Pa				
Energy classification filters		ePM1 65% (F7) ePM10 65% (M5)				
Filter pressure switch		present				
Sound power level ⁽³⁾	dB(A)	70,0	72,0	67,0	68,0	72,0
Sound pressure level ⁽⁴⁾	dB(A)	58,0	60,0	55,0	56,0	60,0
Power supply	V/ph/Hz	400/3/50				

⁽¹⁾ ratio between the thermal gain of the inlet air (0 °C) and the thermal loss of the exhaust air (20 °C), both referred to the external temperature, measured under dry reference conditions, with balanced mass flow and a thermal difference of the internal/external air of 20K, excluding the thermal gain generated by the fan motors and the internal leakage, in accordance with the provisions of attached V of EU Regulation No 1253/2014

⁽²⁾ performance with clean filters

⁽³⁾ sound power level calculated in accordance with EN 3744

⁽⁴⁾ sound pressure level measured at 1 m free field distance, in accordance with EN 3744

ACCESSORIES

MODEL	010	020	030	045	060	080	100	130	170	240
Filters ePM ₁₀ 60% (M5) on return / ePM ₁ 55% (F7) on supply	■	■	■	■	■	■	■	■	■	■
EC brushless fans on supply/return	■	■	■	■	■	■	■	■	■	■
Filters differential pressure switches	■	■	■	■	■	■	■	■	■	■
Fans differential pressure transducers	■	■	■	■	■	■	■	■	■	■
Microprocessor control system with display	■	■	■	■	■	■	■	■	■	■
RS-485 serial port Modbus protocol	■	■	■	■	■	■	■	■	■	■
50 mm frame or 60 mm thermal break frame	□	□	□	□	□	□	□	□	□	□
40 kg/m ³ polyurethane panels thermal insulation	□	□	□	□	□	□	□	□	□	□
90 kg/m ³ mineral wool panels thermal insulation	□	□	□	□	□	□	□	□	□	□
Filters ePM ₁ 55% (F7) return and/or ePM ₁ 80% (F9) supply/return	□	□	□	□	□	□	□	□	□	□
Pre-filters ePM ₁₀ 50% (G4) on supply/return	□	□	□	□	□	□	□	□	□	□
Return grease ISO Coarse 40% (G2) filter	□	□	□	□	□	□	□	□	□	□
Electric frost coil protection	□	□	□	□	□	□	□	□	□	□
Electric / Water heating coil	□	□	□	□	□	□	□	□	□	□
Cold water/direct expansion coil ⁽¹⁾	□	□	□	□	□	□	□	□	□	□
3 way modulating valve ⁽¹⁾	□	□	□	□	□	□	□	□	□	□
Circular duct flanges (4 pcs)	□	□	□	□	□	□	□	□	□	□
Exhaust/Fresh air damper	□	□	□	□	□	□	□	□	□	□
ON/OFF damper actuator	□	□	□	□	□	□	□	□	□	□
Sound attenuator ⁽¹⁾	□	□	□	□	□	□	□	□	□	□
Roof for outdoor installation	□	□	□	□	□	□	□	□	□	□
45° hoods with bird trap (2 pcs)	□	□	□	□	□	□	□	□	□	□
Flexible joints for duct connections (4 pcs)	□	□	□	□	□	□	□	□	□	□
Remote control panel ⁽²⁾	□	□	□	□	□	□	□	□	□	□
CO ₂ probe (available only for ECO version)	□	□	□	□	□	□	□	□	□	□

⁽¹⁾ mounted in a separated box

⁽²⁾ supplied loose

■ Standard □ Optional – Not available

OPERATING LIMITS

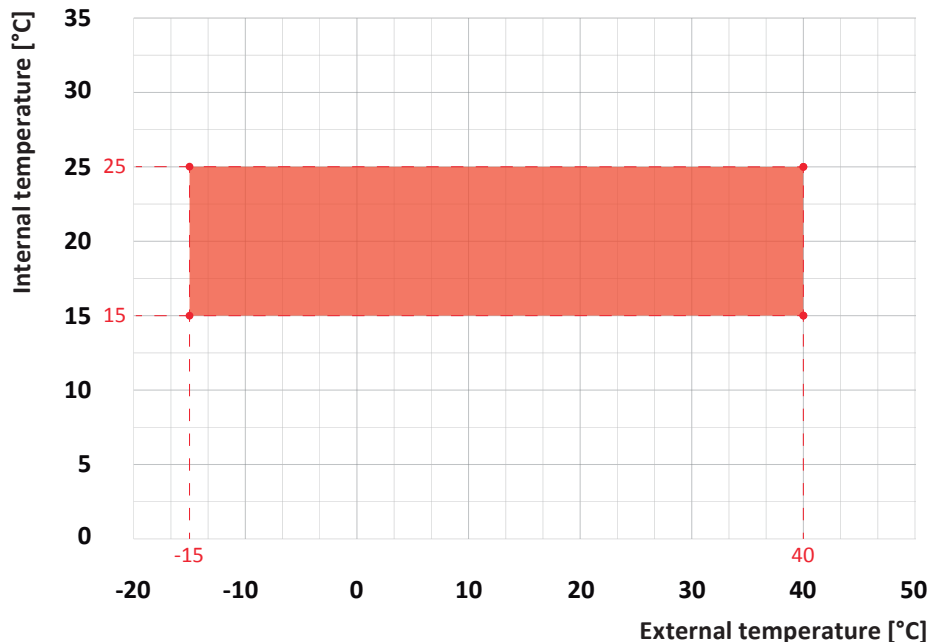

DIMENSIONAL DRAWING

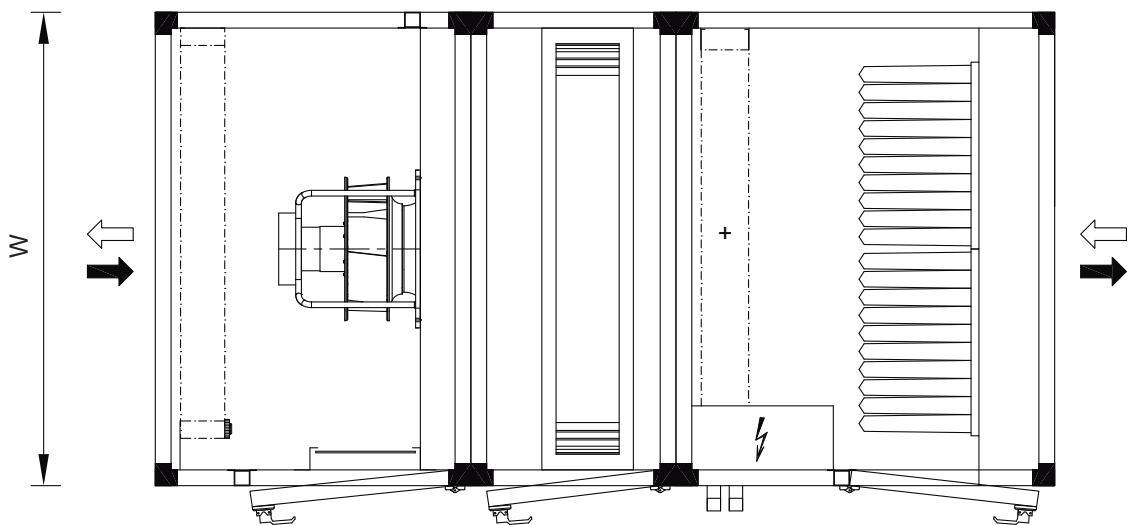
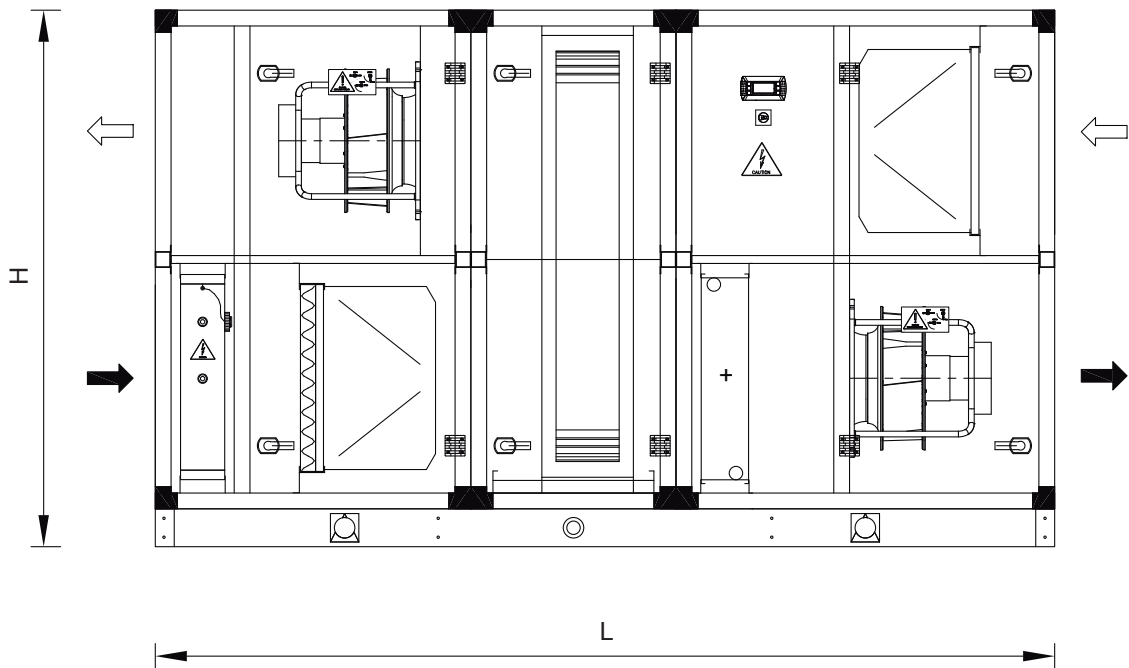

DIMENSIONS AND WEIGHTS

MODEL	010	020	030	045	060	080	100	130	170	240
L (mm)	2250	2250	2550	2550	2850	3100	3150	2950	2950	3100
W (mm)	750	950	1300	1300	1500	1750	1880	1880	2130	2380
H (mm)	1070	1320	1420	1520	1700	1900	2050	2120	2520	2850
Weight (kg)	245	300	410	455	565	760	835	910	1110	1315

Dimensions and weights are referred to standard configuration